

Lenze

EN *Operating Instructions*

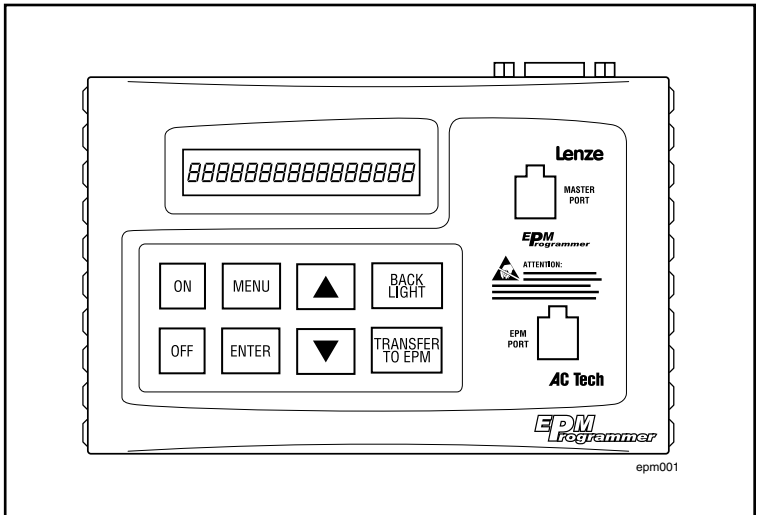

EPM Programmer EEPM1RA

© 2004 Lenze gmbH & CO KG

No part of this documentation may be copied or made available to third parties without the explicit written approval of Lenze GmbH & Co KG.

All information given in this documentation has been carefully selected and tested for compliance with the hardware and software described. Nevertheless, discrepancies cannot be ruled out. We do not accept any responsibility nor liability for damages that may occur. Any necessary corrections will be implemented in subsequent editions.



1	Preface and general information.....	2
1.1	<i>About these Operating Instructions.....</i>	2
1.2	<i>Terminology used.....</i>	2
1.3	<i>EPM Technology and Operation.....</i>	3
1.4	<i>Pictographs used in these Operating Instructions.....</i>	3
1.5	<i>Scope of delivery.....</i>	3
2	Technical data.....	4
2.1	<i>General data and application conditions.....</i>	4
2.2	<i>Electrical Data.....</i>	4
2.3	<i>Dimensions.....</i>	5
3	Commissioning.....	6
3.1	<i>Battery Operation.....</i>	6
3.2	<i>Changing Batteries.....</i>	6
3.3	<i>Operation with external power supply.....</i>	7
4	Operation.....	8
4.1	<i>Overview of operating elements.....</i>	8
4.2	<i>Key Functions.....</i>	8
4.3	<i>Switch on/off EPM Programmer.....</i>	9
4.4	<i>Select Language.....</i>	10
4.5	<i>Switch on/off display background illumination.....</i>	10
4.6	<i>Menu Overview.....</i>	11
4.7	<i>Copy from one EPM to another EPM.....</i>	12
4.8	<i>Copy a file stored in the Programmer to an EPM.....</i>	13
4.9	<i>Edit the EPM.....</i>	14
4.10	<i>Edit a file stored in the Programmer.....</i>	15
4.11	<i>Create a new file.....</i>	16
4.12	<i>Delete a file stored in the Programmer.....</i>	17
4.13	<i>Change EPM Programmer Internal Configuration.....</i>	17
4.14	<i>Contrast setting.....</i>	18
4.15	<i>Display status messages.....</i>	18
4.16	<i>Enter/change password.....</i>	19
5	Troubleshooting.....	20
5.1	<i>Error messages.....</i>	20



Preface and general information

1 Preface and general information

The EEPM1RA EPM programmer enables you to easily duplicate and archive the memory and configuration of inverter drives and servo controllers that utilize the EPM feature.

The EEPM1RA EPM programmer enables you to:

- copy the contents of one EPM to another EPM,
- read out contents of EPMs and save them to a PC or the EPM programmer as files,
- edit files stored in the EPM programmer,
- store edited files under another file name and create new files,
- copy files stored in the EPM programmer into EPMs.

1.1 About these Operating Instructions

This documentation applies to the EPM Programmer as of version:

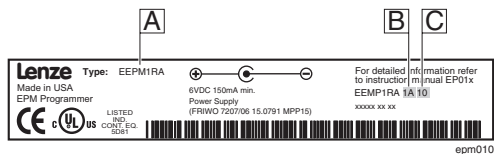

A	Type	EEPM1RA
B	Hardware version	1A
C	Software version	10

- These Operating Instructions are designed to ensure safe and trouble-free working with the EEPM1RA EPM programmer.
- Before you start working with the EEPM1RA EPM programmer, please read the Operating Instructions carefully and follow the notes.
- These Operating Instructions must always be kept as a complete legible document.

1.2 Terminology used

Term	Meaning in this document
Drive controller	Lenze or AC Tech submicro frequency inverter
Servo controller	Lenze Model 94 SimpleServo



1.3 EPM Technology and Operation

The EPM uses EEPROM technology housed in a removable plastic casing for protection and ruggedness. A removable memory structure, as provided by an EPM include:

- Programming a drive without power.
- Easily duplicate proven programs using the EPM Programmer.
- Reduce down-time and troubleshooting.

The EPM feature is included with several Lenze and AC Tech inverter drive controllers and in the new SimpleServo products. Operation and some functionality differ between the Drive and Servo product lines.

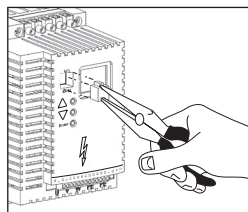

epm011

Drive Controllers	EPM Color: Blue EPM files can be stored in EPM Programmer
Servo Controllers	EPM Color: Blue (Model 94) EPM files cannot be stored in EPM Programmer

OEM Defaults

The EPM, when used in Inverter Drive Controllers, actually contains two sets of drive parameters. The USER memory is the memory the drive typically uses for operation and is actually the drives operating memory that can be accessed and changed from the front of the drive, a remote keypad or serial communications. The OEM Default values can only be written by the EPM Programmer and cannot be altered through normal drive operation or programming. This provides a benefit in that an OEM using the EPM Programmer to quickly copy the drive configuration, actually ships the drive with their own "Factory Defaults".

Lenze Servo Controllers are programmed using MotionView94 Software via serial link with a PC. Field reprogramming from the front of the controller is not possible. As such, resetting to OEM defaults is impossible and this second memory set is not used.

1.4 Pictographs used in these Operating Instructions

Pictograph used	Signal words	
	Stop!	Warns of possible malfunctions of the EPM Programmer due to electrostatic discharge (ESD)
	Tip!	Designates a general and useful note. If observed, it will make using the EPM Programmer easier.

1.5 Scope of delivery

Scope of delivery	Important
<ul style="list-style-type: none"> • 1 EEPROM1RA EPM programmer with 4 batteries (already installed) • 1 Operating Instructions 	<p>After receipt of the delivery, check immediately whether the items delivered match the accompanying papers. Lenze does not accept any liability for deficiencies claimed subsequently.</p> <p>Claim</p> <ul style="list-style-type: none"> • visible transport damage immediately to the forwarder. • visible deficiencies / incompleteness immediately to your Lenze representative.



Technical data

2 Technical data

2.1 General data and application conditions

Field	Values
Type of Protection	IP20
Permissible temperature ratings	Operation 0 ... +50 °C Transport -20 ... +60 °C Storage -20 ... +60 °C
Humidity	<85 %, without condensation
Weight	1.3 kg with batteries
Applied Standards	Noise emission to EN 50081-2: 1993 Noise immunity to EN 61000-6-2 : 1999
Approvals	UL 508C Underwriters Laboratories Power Conversion Equipment
Conformity	CE EMC Directive (89/336/CEE)

2.2 Electrical Data

Field	Values	
DC Voltage Supply		+ 6 VDC, min. 150 mA
	Internal Batteries	4 mono-cells (type D), 1.5 VDC each
	External power supply unit	+ 6 VDC, 300 mA
Display	Type	LCD
	Display format	Text
	Lines x characters	1 x 16
	Contrast setting	Via menu
Memory	Data Memory	up to 120 parameter files for inverter drive controllers
Serial Interface	DB9 Connector	RS232



2.3 Dimensions

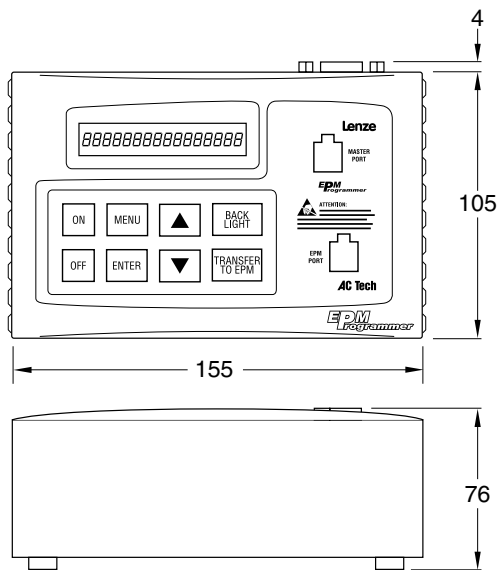

epm001

Dimensions in mm



Commissioning

3 Commissioning

3.1 Battery Operation

The EPM programmer is immediately ready for operation. It is delivered with 4 batteries (1.5 V mono-cells).

3.2 Changing Batteries

For battery operation you need four mono-cell (D size) with 1.5V each. In order to access the battery compartment, you must open the housing of the EPM programmer.

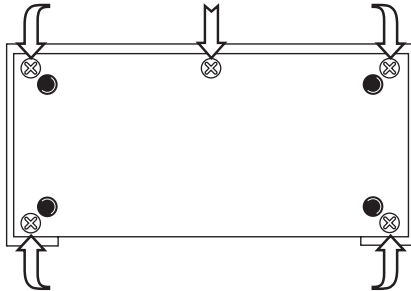

epm007

Open the battery compartment of the EPM programmer

1. Remove the 5 screws on the bottom of the EPM programmer
2. Remove the EPM Programmer base plate carefully.

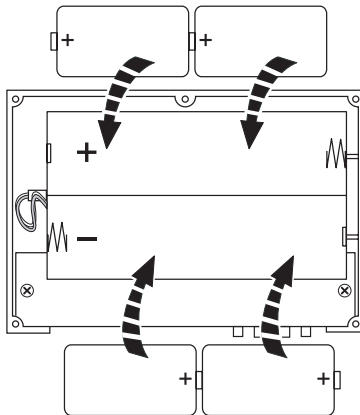

epm004

Insert the batteries into the battery compartment

1. Insert the batteries into the battery compartment as shown in figure above.
 - Pay attention to the correct polarity of the batteries!
2. Replace the base plate carefully and secure the housing with the 5 screws.



3.3 Operation with external power supply



Stop!

- Avoid electrostatic discharges (ESD) at the connector for the voltage supply. EPM programmer malfunction may occur.
- Take appropriate measures to avoid electrostatic conditions.
- Occasionally occurring malfunctions can normally be remedied by switching the EPM Programmer off and then on again.

It is also possible to operate the EPM programmer with an external power supply.

Power supply output data:

- Output voltage: 6 VDC, stabilized
- Output current: 300 mA

Power supply connector plug details

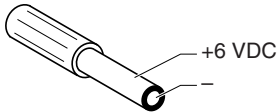

epm005

For connections to the EPM programmer the power supply unit requires an extra-low voltage plug with the following dimensions: 2.1 x 5.5 x 9.5 mm.

Connect the power supply unit

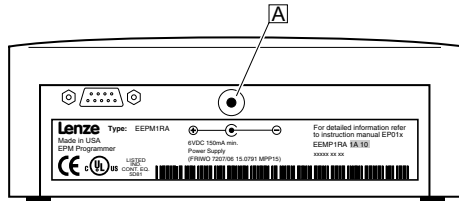

epm006

Plug the extra-low voltage plug of the power supply into the **A** connector at the back of the EPM Programmer



Operation

4 Operation

4.1 Overview of operating elements

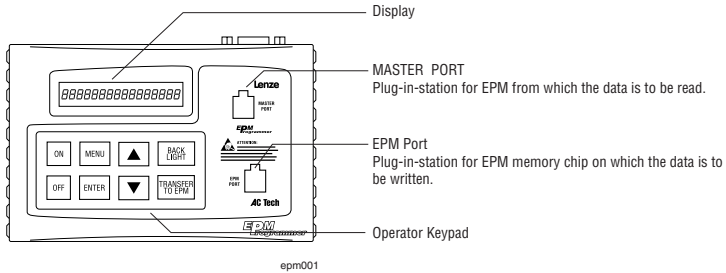

4.2 Key Functions

Key	Function
	Switch on EPM programmer
	Switch off EPM programmer
	Menu level: Select menu, quit submenu Parameter level: Return to the main menu without saving changes
	Menu level: Select submenu, execute menu command Parameter level: Select parameter to enter a value, accept a value entered
	Menu level: Select submenu/file Parameter level: Enter a higher value
	Menu level: Select submenu/file Parameter level: Enter a lower value
	Switch on/off background illumination for the display
	Transfer data to EPM PORT



4.3 Switch on/off EPM Programmer

Switch-on with unprotected access (without password)

Press	The display shows...	Explanation
1.	EPM PROGRAMMER	
2.	INTERN CFG 400	Shows the parameter version that the EPM programmer is configured with (e.g. 400).
3.	MASTER CFG 400	Shows the parameter version of the EPM (e.g. 400) plugged into the MASTER PORT.
4.	MSTFILE#DEFAULTS	Shows the name of the parameter file (e.g. DEFAULTS) stored in the EPM plugged into the MASTER PORT.
	MASTER MISSING!	This message is displayed, if no EPM is plugged into the MASTER PORT.

Switch-on with protected access (with password)

Steps 1...4 as above (Section 4.16, Enter/change password)

Press	The display shows...	Explanation
5.	PASSWORD?? 0000	The cursor is blinking in the display on the right. Enter the password using the ▲▼ buttons.
6.	PASSWORD?? xxxx	If you do not enter a password, you have restricted access to the main menus after confirmation (only the menus CONTRAST, DISPLAY, and MASTER -> EPM are available). If you enter a wrong password, WRONG PASSWORD will be displayed. If you press the MENU key, you abort the process and get the restricted access to the main menus.



Tip!

- After the initialization, the main menu shown last is automatically called up.
- If you lose or forget your password, please contact your Lenze representative.

Switch-off

Press	The display shows...	Explanation
1.	SHUTDOWN.. 5SEC	The shutdown process takes 5 seconds. If you press any key within these 5 seconds, the shutdown process is aborted



Tip!

- The EPM programmer automatically turns off after 5 minutes, if no operation takes place during this time.



Operation

4.4 Select Language

You can choose between English, German, French, Italian and Spanish languages.

- The language change over can be carried out on the menu level and parameter level.
- The language set remains stored even after switching off the EPM Programmer.



Press	The display shows...	Explanation
1. 		Press and hold the ON button. The languages will scroll in 5 second intervals in the sequence: English, German, French, Italian, Spanish. Release ON button when desired language is displayed.



Tip!

- Languages are a part of the product "Configuration File". If, when changing the internal configuration (section 4.13), the new configuration file does not contain the selected language, English will be displayed.

4.5 Switch on/off display background illumination

Press	The display shows...	Explanation
1. 		The background illumination is switched on.
2. 		The background illumination is switched off.



Tip!

- If you operate the EPM programmer with a power supply unit, the background illumination will always be switched on.

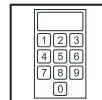

4.6 Menu Overview

After power is switched on and the initialization screens have been displayed, the primary functions of the EPM Programmer are accessed by pressing the MENU button.

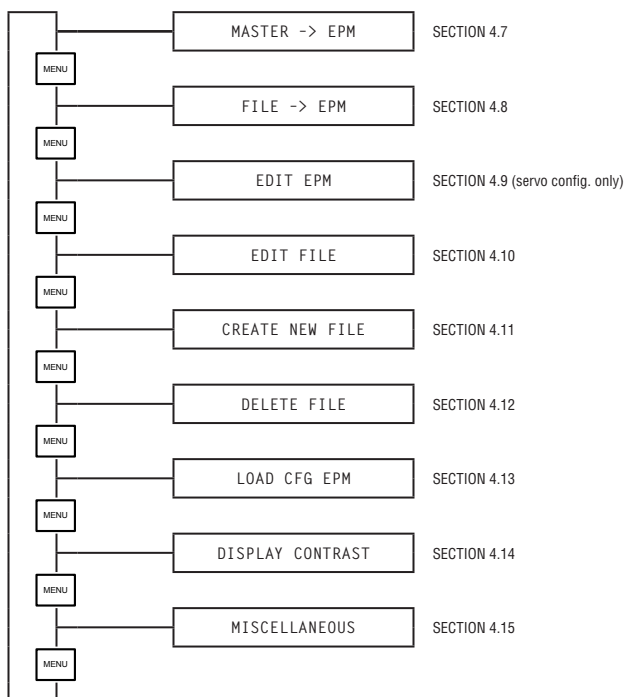

Tip!

- When copying to an EPM using MASTER->EPM or FILE->EPM, all data on the target EPM will be overwritten.

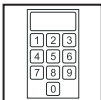

Operation

4.7 Copy from one EPM to another EPM

With this function it is possible to copy a parameter file directly from one EPM (a "Master") to another EPM.

- Plug the EPM containing the parameter file you want to copy into the MASTER PORT.
- Plug the EPM, to which you want to copy the parameter file, into the EPM PORT.

	Press	The display shows...	Explanation
1.		MASTER -> EPM	Press the key until the menu appears in the display.
2.		#DEFAULTS(400)>>	The name of the parameter file (e.g. DEFAULTS) of the EPM in the MASTER PORT is displayed. The parameter version of the file is shown in parenthesis.
3.		TRANSFERRING 0% DAT=400 EPM=312 CONFIRM= [ENTER]	The parameter file is copied or... ...if the parameter version of the file does not correspond with the parameter version of the EPM in the EPM PORT,a security check takes place concerning the existing data on the EPM: Press the ENTER key to overwrite the existing data. Press the MENU key, if you want to abort the process.
4.		TRANSFERRING 100% #DEFAULTS(400)>>	The parameter file will be copied.
5.		MASTER -> EPM	Returns to the main menu.



Tip!

- The file name on the MASTER EPM, is only displayed if the user parameters exactly match the OEM Default parameters (see Section 1.3, EPM Technology and Operation).
- If the user and OEM memory areas do NOT match, the name of the parameter file of the EPM in the MASTER PORT will be displayed as #***** (400)>>. This indicates that the user parameters have been changed from the OEM defaults or the Factory Defaults.
- Copy from MASTER -> EPM will copy only the user parameter file from the MASTER and save this to both the user and OEM memory locations of the EPM in the EPM PORT. The parameter file name of the new EPM will be displayed as #?????? (400)>>.
- Servo controllers do not store OEM defaults, so the parameter file name in the master will always be displayed as ***** (16384)>.



4.8 Copy a file stored in the Programmer to an EPM

With this function it is possible to copy a parameter file saved in the EPM programmer to an EPM.

- Plug the EPM, to which you want to copy the parameter file, into the EPM PORT.

	Press	The display shows...	Explanation
1.		FILE -> EPM	Press the key until the menu appears in the display.
2.		#DEFAULTS(400)>>	The stored name of a parameter file (e.g. DEFAULTS) stored in the EPM programmer, is displayed.
3.		#DEFAULTS(400)█>>	The cursor is blinking in the display on the right.
4.		#ABC_____(400)█>>	Select the parameter file you want to copy (e.g. ABC____).
5.		TRANSFERRING 0%	The parameter file is copied or..
		DAT=400 EPM=312	...if the parameter version of the file does not correspond with the parameter version of the EPM in the EPM PORT,...
		CONFIRM= [ENTER]	...a security check takes place concerning the existing data on the EPM: Press the ENTER key to overwrite the existing data. Press the MENU key, if you want to abort the process.
6.		TRANSFERRING 100%	The parameter file will be copied.
		#ABC_____(400)>>	
7.		FILE -> EPM	Returns to the main menu.



Operation

4.9 Edit the EPM

This menu item is only displayed when the EPM Programmer is configured for a Servo product.

With this function it is possible to edit PPP BAUDRATE, NETWORK ADDRESS, CAN NODE ID, and CAN BAUDRATE for Model 94 Servo drives.

	Press	The display shows...	Explanation
1.		EDIT EPM	Press the key until the menu appears in the display.
2.		EPM INFO	This request is briefly shown in the display.
		*****{16384}>	The EPM parameter version is displayed.
		CAN NODE ID	Displays the parameters that can be edited
		NETWORK ADDRESS	Select the parameter file you want to Edit (NETWORK ADDRESS is shown as an example)
4.		NET ADDR 3	The cursor is blinking in the display on the right
		NET ADDR	Change the parameter
		NETWORK ADDRESS	Stores the new value onto the EPM
		EDIT EPM	Returns to the main menu.



Tip!

- The EPM can only be edited if the configuration of the EPM Programmer and the parameter version of the EPM are identical. See section 4.13 for changing the configuration of the EPM Programmer.

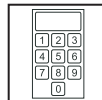

4.10 Edit a file stored in the Programmer

With this function it is possible to edit an Inverter Drive controller parameter file stored in the EPM programmer.

Press	The display shows...	Explanation
1.	EDIT FILE	Press the key until the menu appears in the display.
2.	SELECT FILE	This request is briefly shown in the display.
	>#DEFAULTS (400)◀	The cursor is blinking in the display on the right. The file name of a parameter file (e.g. DEFAULTS) is displayed.
3.	>#ABC_____ (400)◀	Select the parameter file you want to edit (e.g. ABC_____).
4.	A: DATA FILE NAME	The cursor is blinking in the display on the left. The first entry which can be edited is displayed (e.g. DATA FILE NAME). Press ENTER to edit the file name: <ul style="list-style-type: none"> • Use ▲▼ buttons to change letters • Use ENTER to move to next letter • Pressing ENTER at the last character stores the name, press MENU to abort
	B: MOP SAVED FREQ or B: KEYPAD SPEED	This parameter sets the initial run speed when the speed source is either MOP or KEYPAD. Press ENTER to access and ▲▼ to adjust.
	C: DIRECTION	Selects default direction for the motor when controlled by a remote keypad.
	XX: PARAMETER	Sequence through the parameters available for the configuration loaded into the programmer. Press ENTER to edit the parameter: <ul style="list-style-type: none"> • Use ▲▼ buttons to change selection or value • Press ENTER to store the new value or press MENU to abort
	EDIT FILE	Returns to the main menu.



Tip!

- The parameter file DEFAULTS is write protected.
 - If you want DEFAULTS to be the basis for editing, create a copy of this file (see section 4.11).
- A file can only be edited if the configuration of the EPM Programmer and the parameter version of the file (shown in parenthesis) are identical. If these two are not the same, this will result in the error message FILE VER INCOMP! See section 4.13 for changing the configuration of the EPM Programmer.

















Operation

4.11 Create a new file

With this function you create a new parameter file in the EPM programmer. Data for your new file can be copied from the following sources:

- Parameter files available on the EPM programmer.
- Parameter file from an EPM mounted in the MASTER PORT.

Press	The display shows...	Explanation
1. 	CREATE NEW FILE	Press the key until the menu appears in the display.
2. 	ENTER FILE NAME	This request is briefly shown in the display
	NAME: _ _ _ _ _	The cursor is positioned under the first character of the file name. A file name can consist of 8 characters maximum.
3.  	NAME: A _ _ _ _ _	Use the ▲▼ buttons to select a value. To scroll quickly to a value, keep the key pressed. The scroll rate increases as you hold the button.
4. 	NAME: A _ _ _ _ _	The cursor is positioned under the next character of the file name.
5.	NAME: ABC _ _ _ _ _	Repeat step 3. until the desired name is entered.
6. 	NAME: ABC _ _ _ _ _	Press ENTER until the cursor is positioned on the eighth character position. If you re-press ENTER, the file name is stored.
	COPY DATA FROM . .	Press MENU at any time to abort the file creation and return to the main menu.
7.  	1) FILE 	The cursor is blinking in the display on the right. Select a source (e.g FILE) whose parameters you want to copy into your new file: 1) FILE 2) MASTER
8. 	SELECT FILE	(this message is not displayed when selecting MASTER and steps 8 and 9 are skipped)
	>#DEFAULTS(400) 	The cursor is blinking in the display on the right.
9.  	>#ABC _ _ _ _ (400) 	Select a parameter file you want to copy (e.g. ABC _ _ _ _). Press the MENU key, if you want to abort this procedure.
10. 	TRANSFERRING 100%	The new file has been created.
	FILE CREATED!	
	CREATE NEW FILE	The EPM programmer automatically returns to the main menu.



4.12 Delete a file stored in the Programmer

With this function you delete the parameter files stored in the EPM Programmer

	Press	The display shows...	Explanation
1.		DELETE FILE	Press the key until the menu appears in the display.
2.		SELECT FILE	This request is briefly shown in the display
		>#DEFAULTS(400)◀	The cursor is blinking in the display on the right.
3.		>#ABC_ _ _ _ _ (400)◀	Select the parameter file you want to delete (e.g. ABC_ _ _ _ _).
4.		CONFIRM=[ENTER]	Press the MENU key, if you want to abort the process.
5.		DELETING FILE... FILE DELETED! DELETE FILE	The parameter file is deleted. The EPM programmer automatically returns to the main menu.

4.13 Change EPM Programmer Internal Configuration

With this function, you can change the type of files that the EPM Programmer can EDIT by downloading the proper configuration for the file you will be working with from a "Configuration EPM" loaded in the MASTER PORT.

	Press	The display shows...	Explanation
1.		LOAD CFG EPM	Press the key until the menu appears in the display.
2.		VERIFYING MASTER	The programmer verifies that the EPM in the MASTER PORT is a valid Configuration EPM.
		CONFIRM=[ENTER]	Press the ENTER button to confirm this action
3.		TRANSFERRING 0% . . . 100%	The new configuration is loaded into the EPM Programmer's memory and verified.
4.		WAIT - LOADING CFG CFG LOADED! LOAD CFG EPM	Messages are displayed briefly then the EPM programmer automatically returns to the main menu.



Tip!

- Changing the EPM Programmer's internal configuration is only required if you are going to EDIT an inverter drive file stored in the EPM Programmer or EDIT a servo drive EPM. The Programmer must be configured for the parameter version of the file.
- Configuration EPM's can be purchased from Lenze, AC Tech or your local distributor.
- Configuration files can be downloaded into the EPM Programmer from your PC via RS232 connection using TECHLINK software.



Operation

4.14 Contrast setting

With this function, you can adjust the viewing angle for the EPM Programmer display.

	Press	The display shows...	Explanation
1.		DISPLAY CONTRAST	Press the key until the menu appears in the display.
2.		CONTRAST MEDIUM	The currently set value is indicated (e.g. MEDIUM).
3.		CONTRAST MEDIUM	The cursor is blinking in the display on the right.
4.		CONTRAST XXXXX	Select the setting wanted: CONTRAST LOW CONTRAST MEDIUM CONTRAST HIGH
5.		CONTRAST LOW	The setting selected (e.g. LOW) is accepted. The cursor stops blinking.
6.		DISPLAY CONTRAST	Returns to the main menu..

4.15 Display status messages

With this function, you can set the Programmer's password and view other important information.

	Press	The display shows...	Explanation
1.		MISCELLANEOUS	Press the key until the menu appears in the display.
2.		S/W VERSION X.XX	Takes you to the submenu. The software version (e.g. 1.00) of the EPM programmer is displayed.
3.			With the you can select the status messages.
4.		INTERN CFG 400	Shows the parameter version that the EPM programmer is configured for (e.g.400).
5.		FILES: 1	Indicates the number of parameter files saved in the EPM programmer.
6.		BATTERY: 5.8VDC	Displays the current voltage level of the 4 internal batteries. To guarantee safe operation, the battery voltage must not fall below 3.6 VDC.
7.		PASSWORD: 0000	Displays the set password for the access protection (Lenze setting: 0000), entering and changing the password is described in the next section.
8.		MISCELLANEOUS	Returns to the main menu.



4.16 Enter/change password

When a password has been set, only the main menus can be accessed until the correct password has been entered.

- MASTER -> EPM
- DISPLAY CONTRAST
- MISCELLANEOUS (without the submenu PASSWORD).

	Press	The display shows...	Explanation
1.		MISCELLANEOUS	Press the key until the menu appears in the display.
2.		S/W VERSION X.XX	Takes you to the submenu. The cursor is blinking in the display on the left.
3.		PASSWORD: 0000	Displays the set password for the access protection (Factory setting: 0000). When the password is set to 0000, the access protection is deactivated.
4.		PASSWORD: 0000	The cursor is blinking in the display on the right.
5.		PASSWORD: XXXX	Enter a password. Any value between 0000 and 9999. Use the ▲▼ buttons to select a value. To scroll quickly to a value, keep the key pressed. The scroll rate increases as you hold the button.
6.		PASSWORD: XXXX	The cursor is blinking in the display on the left. The new password has been stored.
7.		MISCELLANEOUS	Returns to the main menu.



Troubleshooting and fault elimination

5 Troubleshooting

5.1 Error messages

Display	Cause	Remedy
CHANGE BATTERY!	The battery voltage is <math><3.6V</math> (the message is displayed after switching on the EPM programmer.	Change the batteries (See Section 3.2)
FILE VER INCOMP!	The parameter file or servo EPM you are attempting to edit has a different parameter version than the configuration file of the EPM programmer.	You can only edit a file if the parameter version corresponds to the configuration file of the EPM programmer. See Section 4.13 on changing the programmers internal configuration.
READ ONLY FILE!	You have tried to edit or delete the file DEFAULTS.	The file DEFAULTS cannot be edited or deleted.
EPM DAMAGED!	The EPM in the EPM PORT is defective. The EPM is not placed correctly in the EPM PORT.	Exchange the defective EPM. Plug the EPM correctly in the PORT.
EPM MISSING!	There is no EPM in the EPM PORT to which you are attempting to transfer data or edit..	Press the menu key now to return to the main menu. Plug an EPM in the EPM PORT.
EPM TOO SMALL!	EPM in EPM PORT does not have sufficient memory for the file you are attempting to copy.	Replace the EPM in the EPM PORT with an EPM that has a higher memory capacity.
INTERNAL ERROR!	Internal device error.	Please contact your Lenze representative.
INVALID INT CFG	The configuration file of the EPM programmer is invalid. Attempting to reconfigure the EPM programmer without a valid configuration EPM.	Please contact your Lenze representative. Insert a valid configuration EPM into the MASTER PORT. See section 4.13.
WRONG PASSWORD	The access protection is activated and you have entered the wrong password after switch-on.	Only if you enter the correct password will you have full access to the main menus. If you press the MENU key, the process is aborted and you have only restricted access to the main menus. (see Section 4.16) If you have forgotten your password, please contact your Lenze representative.

Troubleshooting and fault elimination



Display	Cause	Remedy
MASTER DAMAGED!	The EPM in the MASTER PORT is defective.	Press the menu key to return to the main menu. Plug an EPM in the MASTER PORT.
	The EPM is not placed correctly in the MASTER PORT.	The message does not indicate an error but only serves as a note. The message is only displayed for a short time.
MASTER MISSING	Seen on power-up if there is no EPM in the MASTER PORT.	Information only.
	Programmer is trying to read data from the MASTER PORT but cannot detect an EPM in this PORT.	Insert a valid EPM into the MASTER PORT.
INVALID MASTER!	The EPM you are attempting to read in the MASTER PORT is defective or has no valid data.	Press the menu key now to return to the main menu. Exchange the EPM in the MASTER PORT.
	The EPM in the MASTER PORT is a Configuration EPM.	A Configuration EPM cannot be copied.
NAME EXISTS!	The file name you want to allocate to a parameter file already exists.	Select another file name.
MEMORY FULL	The internal memory of the EPM programmer is full.	It is not possible to save any more parameter files. If necessary, delete parameter files you do not need anymore.
TRANSFER FAILED	Error in the data transmission to the EPM PORT, because the memory chip is defective, or is not placed correctly in the PORT.	Exchange the defective EPM or plug the EPM correctly in the PORT.
	Attempted MASTER -> EPM transfer when- the memory size of the MASTER EPM is different from that of the target.	Replace the EPM in the EPM PORT with an EPM of the same color as the Master.
	Error in the data transmission to the EPM PORT, because of an internal error in the EPM programmer.	Please contact your Lenze representative.
INVALID OPTION!	Attempted to CREATE a new file from a servo drive EPM in the MASTER PORT.	Only inverter drive EPM's can be saved as files in the EPM Programmer.
INVALID EPM!	Attempted to EDIT a non-servo EPM or a corrupted servo EPM.	Replace the EPM in the EPM PORT with a valid servo EPM.
NO FILES	Attempting to EDIT, DELETE or CREATE a file, but there are no stored files in the EPM Programmer.	
CFG EPM MISSING!	Attempt to LOAD CFG EPM without a valid configuration EPM in the MASTER PORT.	Insert a configuration EPM into the MASTER PORT.



Notes

Lenze

AC Technology Corporation

630 Douglas Street
Uxbridge, MA 01569 • USA

 +1 (508) 278-9100