



# Q75 SELEZIONE & DIMENSIONI / SELECTION & DIMENSIONS



FI. mot. disponibili / Available motor flanges

\*n<sub>1</sub> = 1400 min<sup>-1</sup>

Tipo Type	n <sub>2</sub> [min <sup>-1</sup> ]	i	P <sub>1M</sub> [kW]	M <sub>2M</sub> [Nm]	f.s.	P <sub>1R</sub> [kW]	M <sub>2R</sub> [Nm]	B5						B14					RD	Mn		Tipo Type			
								A	B	C	D	E	F	O	P	Q	R	T					U		
								56	63	71	80	90	100 112	56	63	71	80	90					100 112		
Q75	200	7	4	170	1.1	4.3	190				B	B							B	B		90	3.75	01	Q75
	140	10	4	240	1.0	4	230				B	B							B	B		88	3.75	02	
	93	15	3	260	1.0	2.8	250				B	B							B	B		85	3.75	03	
	70	20	2.2	249	1.0	2.1	250				B	B							B	B		83	3.00	04	
	56	25	1.5	205	1.2	1.7	250				B	B							B	B		80	2.41	05	
	45	31	1.5	245	1.1	1.65	270			B	B								B	B		77	3.75	06	
	35	40	1.5*	295	0.9	1.27	255			B	B								B	B		72	3.10	07	
	28	50	0.75	174	1.3	0.93	220			B	B								B	B		68	2.41	08	
	23	60	0.75	202	1.0	0.75	200			B	B								B	B		65	2.10	09	
	18	80	0.55	172	1.0	0.55	180			B	B								B	B		59	1.53	10	
14	100	0.55	206	0.7	0.44	150			B	B								B	B		55	1.23	11		

\* Potenza superiore a quella massima sopportabile dal riduttore. Selezionare in base al momento torcente M<sub>2R</sub> [Nm]

\* Power higher than the maximum one which can be supported by the gearbox. Select according to the torque M<sub>2R</sub> [Nm]

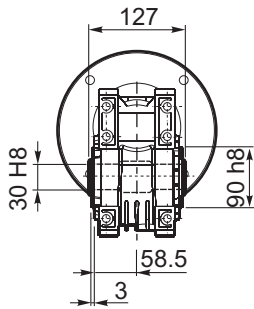

M... \FB

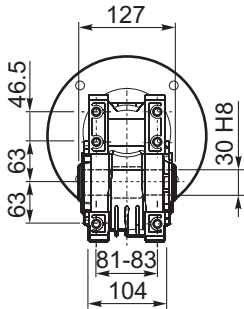
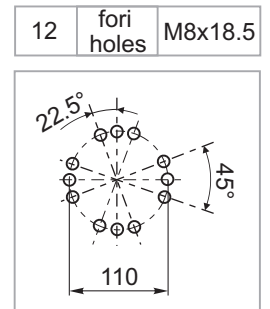
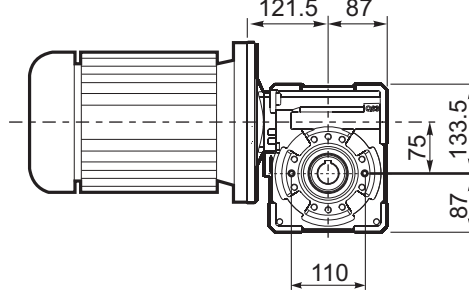

M... \FC

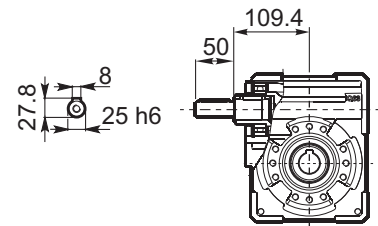
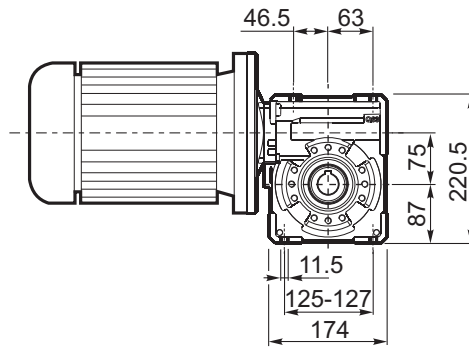

R...

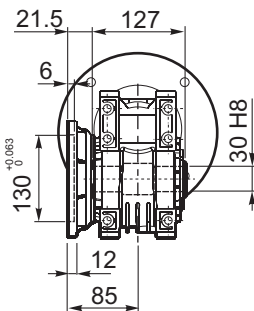

M... \FL

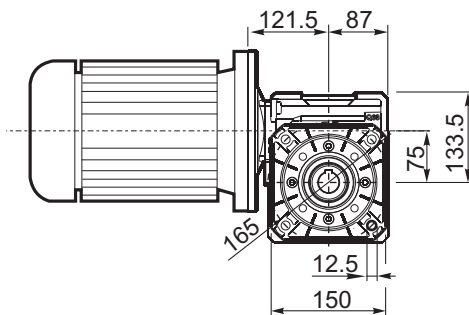

## ALBERO USCITA OUTPUT SHAFT

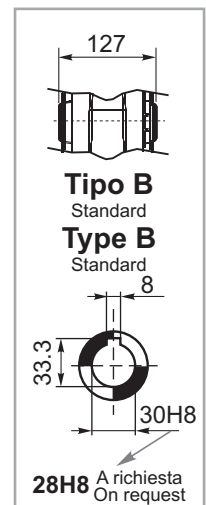

Wormbox weight Peso riduttore	<b>Kg</b>
<b>Q75</b>	<b>8,73</b>

B) Supplied with reduction bushing - Montaggio con boccola di riduzione

B) Available on request without reduction bushes

\* Disponibile a richiesta anche senza boccola di riduzione

\* 2 poles (2800 rpm) only for very intermittent use - Usare i motori a due poli solamente per uso intermittente.

C) Motor flange holes position/terminal box position  
Posizione fori flangia/basetta motore

